

Angled Protection Post

Our angled protection post is the ideal cost effective solution for protecting expensive and fragile equipment within your environment.

It is stylish and clean in appearance, the post is available in galvanised steel or chrome, offering the perfect combination of form and function. The angular design enables it to be located snugly against your equipment, maximising both protection and floor space.

Securely bolted to the floor with external fixings to ensure easy of installation, it's generous 600mm height makes the angled protection post perfect for exposed corners such as refrigeration units or racking.

Standard and optional features;

Design:

- 115mm x 115mm
- 600mm overall height
- Fabricated using 5mm mild steel
- Comes complete with external fixings as standard
- Chrome or Galvanised steel versions available

Positioning Guidelines:

- Place approximately 20mm from surface to be protected
- Fixed using M10 x 80 floor fixings
- Internal fixings are available at special request

Bayonet Fixing

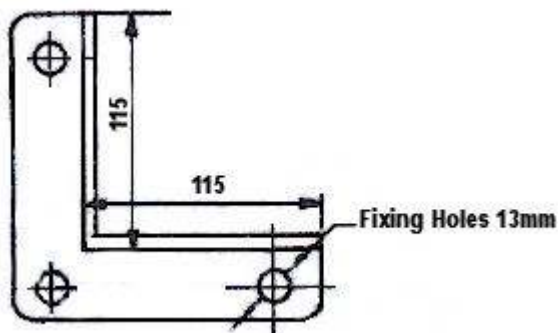

Order Information

Can be supply only or fully installed

