

Modular Guard Rail

Our modular guard rail can be easily assembled and installed in long unbroken runs or fabricated with corner bends and 'U' ends for access points and around site hazards. For a professional finish each upright is supplied with two joints in position to take the steel tubes. The steel tube handrail barrier is supplied in our standard length of 3m but on request can be cut to lengths and sizes to suit your site. The handrail has a good overall appearance.

No special tools are required the whole handrail barrier system is assembled with an allen key to tighten and secure steel that are concealed in each of the steel joints.

Assembly is fast, the upright posts are positioned at 1500mm or 2000mm (as shown below) centres. The posts can be either bolted down using sleeve anchor bolts or set into concrete foundations. The planting depth for the steel upright post is 300mm/400mm.

This modular guard rail is hot dipped galvanized after manufacture to provide a weather proof finish that will require little maintenance. The steel can be painted on site, the galvanized finish needs to be neutralized with 'T' acid wash that quickly dries allowing for a top coat of an industrial paint finish.

Standard and optional features;

Design:

- Typical - 1000mm high, can be variable (depending upon location & usage - refer to Local Building Regulations for further advice)
- Centre cross rail
- 48mm diameter tube
- 2No. fixings per upright



Order Information

Can be supply only or fully installed

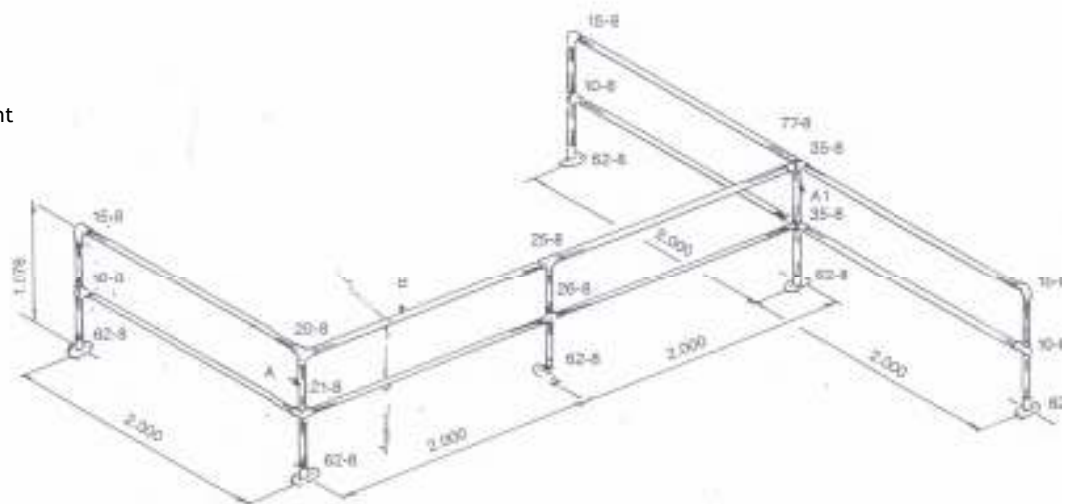

MAXIMUM HANDRAIL LOAD PER METRE = 0,22 KN/M
 CHARGE MAXIMALE DE MAIN-COURANTE PAR MÈTRE = 0,22 KN/M
 MAX. BELÄNDERLAST PRO METER: 0,22 KN/M